

42.7i, 52.7i, 62.7i, 63.7i, 652.7i, 653.7i,
692.7i, 693.7i, 32.7cf, 462.7cfp, 682.7cf

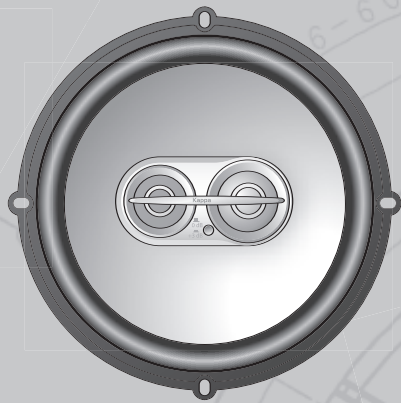
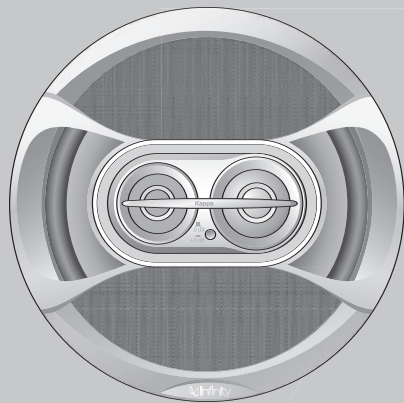

 Infinity[®]

instructions

kappa[®] series

INSTALLATION WARNINGS AND TIPS

THANK YOU for purchasing Infinity's Kappa Series multielement automotive loudspeakers. We've organized this manual to make their installation as simple and trouble-free as possible. Please read it thoroughly before proceeding.

Remember to keep your sales receipt with this manual in a safe place so both are available for future reference.

ABOUT THESE INSTRUCTIONS

Installation of automotive stereo components can require extensive experience with a variety of mechanical and electrical procedures. Although these instructions explain how to install Kappa Series multi-element speakers in a general sense, they do not show the exact installation methods for your particular vehicle. If you do not feel you have the experience, do not attempt the installation yourself, but instead ask your authorized Infinity car audio dealer about professional installation options.

LOUD MUSIC AND HEARING

Playing loud music in an automobile can hinder your ability to hear traffic as well as permanently damage your hearing. The maximum volume levels achievable with Infinity speakers, combined with high power amplification, may exceed safe levels for extended listening. We recommend using low volume levels when driving. Infinity accepts no liability for hearing loss, bodily injury, or property damage as a result of use or misuse of this product.

REAR DECK PRECAUTION

In some cars, fuel tanks may be located directly beneath the rear deck. Before installation, make sure there is adequate speaker basket clearance before considering this location!

ABOUT THE CROSSOVER

Except for the 462.7cfp, each Kappa Series multielement speaker includes a crossover for in-line connection to an amplifier output and is required for proper operation (see Figure 8 on the next page). The attached crossover wires are keyed and color-coded to aid in correct polarity connections. **Do not omit the crossover or substitute another one – doing so will damage the speaker.**

INSTALLATION TIPS

- Always wear protective eyewear when using any tools.
- Turn off all audio components and other electrical devices before you start. Disconnect the (-) negative lead from your vehicle's battery.
- Keep speakers in their package until final installation. When moving a speaker, always rest it with the cone or dome facing up. Never use force to install any speaker.
- Check clearances on both sides of a planned mounting surface before drilling any holes or installing any screws. Remember that the screws can extend behind the surface.
- At the installation sites, locate and make a note of all fuel lines, hydraulic brake lines, vacuum lines and electrical wiring. Use extreme caution when cutting or drilling in and around these areas.
- Before drilling or cutting holes, use a utility knife to remove unwanted fabric or vinyl, to keep material from snagging in a drill bit or saw.
- For door installations, check the clearance with the windows throughout the range of the window's travel, and verify that a mounted speaker will not interfere with the window crank or power window mechanism.
- If mounting speakers elsewhere, check for clearance around rear deck torsion bars, glove box or other structural elements.
- Do not mount speakers where they will get wet.

INSTALLATION

Figure 1. Mounting the 42.7i, 52.7i, 62.7i, 63.7i, 692.7i, 693.7i, 32.7cf or 682.7cf.

NOTE: The 32.7cf, 462.7cfp and 682.7cf speakers are designed to be installed under factory grilles. Consequently, no grilles are packaged with these models.

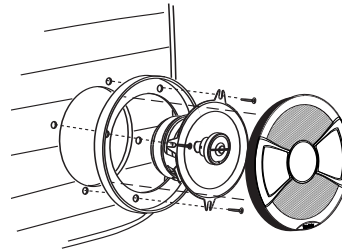

Figure 2. Modifying the 42.7i to be installed in locations requiring fewer than 4 mounting "ears." (The 62.7i and 63.7i may be similarly modified.)

NOTE: Grip the tab with pliers and bend to detach it from the speaker.

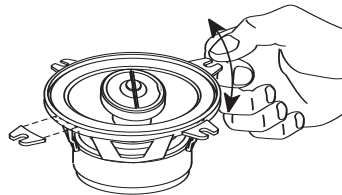

Figure 3. Mounting the 572.7cf or 462.7cfp. The 32.7cf (not shown) is mounted in a similar way.

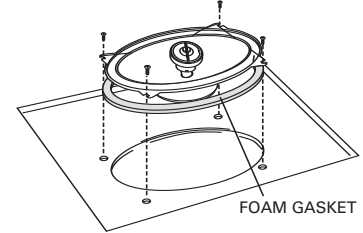
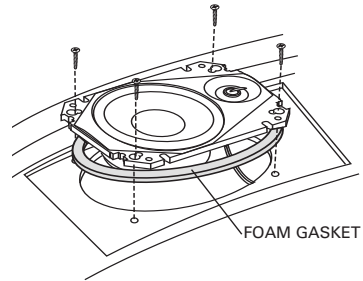

Figure 3a.



INSTALLATION

Figure 4. Mounting the 62.5i with the grille.

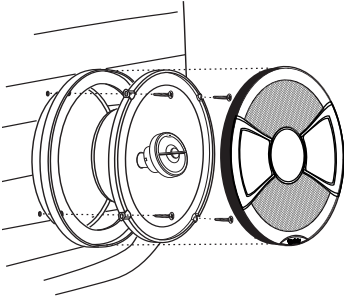

Figure 5. Mounting the 62.5i in a 165mm speaker location.

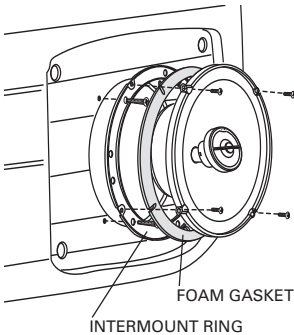

Figure 6. Mounting the 62.5i in a standard speaker location.

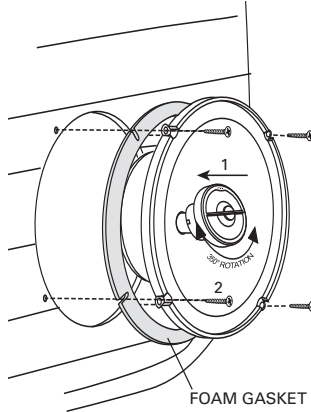
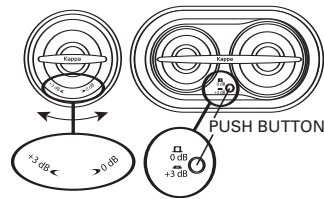

Figure 7. Tweeter level adjustment.



INTERMOUNT III MOUNTING RINGS

The Kappa 62.7 and 63.7 speakers are packaged with two different speaker adaptor rings. The rings will allow the speakers to be installed into various factory 6", 6-1/2" and 6-3/4" openings. See **Figure 5**. The metal ring can be mounted in many European vehicles, Japanese vehicles or vehicles with 6" speaker locations. The plastic ring can be mounted in many vehicles using 6-3/4" speaker locations or three-point mounting frames.

UNIPIVOT™ ROTATING TWEETER

In order to rotate the tweeter on select Kappa speakers, (1) push the tweeter post inward and (2) then rotate. Once in position, release the tweeter to lock in position (**Figure 6**). This feature is only available on the Kappa 52.7, 62.7, 692.7 and 682.7cf speakers.

TWEETER LEVEL ADJUSTMENT

All Kappa series multielement speakers are equipped with an adjustable tweeter level. On all two-way speakers, slightly twist the tweeter faceplate to either the +3dB or 0dB position (**Figure 7**). All three-way speakers have a push button to adjust the tweeter level between the +3dB and 0dB setting (**Figure 7**). Adjust to personal preference.

CONNECTIONS

Figure 8. Connecting an in-line crossover to a 62.7i and an amplifier output. Other speaker models are connected in a similar way.

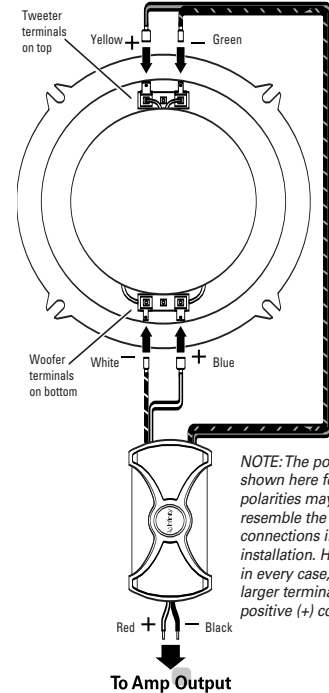

SPECIFICATIONS

42.7i

Type: 4" 2-Way
Speaker Impedance: 2 ohms
Power Handling: 50W RMS, 150W Peak
Sensitivity (2.83V, 1m): 93dB
Frequency Response: 75Hz – 25kHz
Mounting Depth: 1-13/16" (47mm)
Cut-Out Diameter: 3-7/16" (88mm)

52.7i

Type: 5-1/4" 2-Way
Speaker Impedance: 2 ohms
Power Handling: 55W RMS, 165W Peak
Sensitivity (2.83V, 1m): 94dB
Frequency Response: 55Hz – 25kHz
Mounting Depth: 2-1/16" (53mm)
Cut-Out Diameter: 4-11/16" (120mm)

62.7i

Type: 6-1/2" 2-Way
Speaker Impedance: 2 ohms
Power Handling: 75W RMS, 225W Peak
Sensitivity (2.83V, 1m): 95dB
Frequency Response: 45Hz – 25kHz
Mounting Depth: 2-3/16" (56mm)
Cut-Out Diameter: 5" (127mm)

63.7i

Type: 6-1/2" 3-Way
Speaker Impedance: 2 ohms
Power Handling: 75W RMS, 225W Peak
Sensitivity (2.83V, 1m): 95dB
Frequency Response: 45Hz – 25kHz
Mounting Depth: 2-3/16" (56mm)
Cut-Out Diameter: 5" (127mm)

652.7i

Type: 165mm 2-Way
Speaker Impedance: 2 ohms
Power Handling: 75W RMS, 225W Peak
Sensitivity (2.83V, 1m): 95dB
Frequency Response: 45Hz – 25kHz
Mounting Depth: 2-1/4" (58mm)
Cut-Out Diameter: 5-5/8" (143mm)

653.7i

Type: 165mm 3-Way
Speaker Impedance: 2 ohms
Power Handling: 75W RMS, 225W Peak
Sensitivity (2.83V, 1m): 95dB
Frequency Response: 45Hz – 25kHz
Mounting Depth: 2-1/4" (58mm)
Cut-Out Diameter: 5-5/8" (143mm)

692.7i

Type: 6" x 9" 2-Way
Speaker Impedance: 2 ohms
Power Handling: 110W RMS, 330W Peak
Sensitivity (2.83V, 1m): 95dB
Frequency Response: 3-3/16" – 25kHz
Mounting Depth: 5-7/8" x 8-11/16"
Cut-Out Diameter: (150mm x 221mm)

693.7i

Type: 6" x 9" 3-Way
Speaker Impedance: 2 ohms
Power Handling: 110W RMS, 330W Peak
Sensitivity (2.83V, 1m): 95dB
Frequency Response: 35Hz – 25kHz
Mounting Depth: 3-3/16" (81mm)
Cut-Out Diameter: 5-7/8" x 8-11/16"
(150mm x 221mm)

32.7cf

Type: 3-1/2" 2-Way, Custom-Fit
Speaker Impedance: 2 ohms
Power Handling: 35 W RMS, 105W Peak
Sensitivity (2.83V, 1m): 95dB
Frequency Response: 85Hz – 25kHz
Mounting Depth: 1-9/16" (40mm)
Cut-Out Diameter: 3-1/4" (83mm)

462.7cfp

Type: 4" x 6" 2-Way, Custom-Fit Plate
Speaker Impedance: 2 ohms
Power Handling: 60W RMS, 180W Peak
Sensitivity (2.83V, 1m): 94dB
Frequency Response: 75Hz – 25kHz
Mounting Depth: 1-13/16" (47mm)
Cut-Out Diameter: 3-5/8" x 5-3/8"
(93mm x 137mm)

682.7cf

Type: 6" x 8"; 5" x 7" 2-Way, Custom-Fit
Speaker Impedance: 2 ohms
Power Handling: 100W RMS, 300W Peak
Sensitivity (2.83V, 1m): 94dB
Frequency Response: 40Hz – 25kHz
Mounting Depth: 2-1/4" (58mm)
Cut-Out Diameter: 4-7/8" x 7-1/8"
(124mm x 181mm)

A valid serial number is required for warranty coverage.

Features, specifications and appearance are subject to change without notice.

Intermount III patent no. 6,505,705.

Infinity Systems, 250 Crossways Park Drive, Woodbury, NY 11797 USA

516.674.4463 • FAX 516.682.3523 • www.infinitysystems.com

© 2005 Harman International Industries, Incorporated • Part No. KAPSEROM2/05

H A Harman International Company



Declaration of Conformity



We, Harman Consumer Group International
2, route de Tours
72500 Chateau-du-Loir
France

declare in own responsibility that the products
described in this owner's manual are in compliance
with technical standards:

EN 61000-6-3:2001
EN 61000-6-1:2001

Klaus Leberher
Harman Consumer Group International
Chateau-du-Loir, France 2/05